



Radiant Electronics Limited

Rm U,13/F., Block 1, Kinho Ind. Bldg., 14 Au Pui Wan St., Shatin N.T. Hong Kong

www.radisplay.com

E-mail: info@radiant-display.com

Tel:(852)29470031

Fax:(852)29470881

SPECIFICATION FOR LCM MODULE

MODULE NO.: RD12864F

REVISION NO.: A

Customer Approval:

--

	SIGNATURE
PREPARED BY	
VERIFIED BY	
APPROVED BY	



Radiant Electronics Limited

Rm U,13/F., Block 1, Kinho Ind. Bldg., 14 Au Pui Wan St., Shatin N.T. Hong Kong

www.radisplay.com

E-mail: info@radiant-display.com

Tel:(852)29470031

Fax:(852)29470881

RECORDS OF REVISION

Date	Rev.	Description	Page	Design by
2011/8/11	0	New Sample.	-	-
			-	-



Radiant Electronics Limited

Rm U,13/F., Block 1, Kinho Ind. Bldg., 14 Au Pui Wan St., Shatin N.T. Hong Kong

www.radisplay.com

E-mail: info@radiant-display.com

Tel:(852)29470031

Fax:(852)29470881

Contents

1. SPECIFICATIONS

- 1.1 Features**
- 1.2 Mechanical Specifications**
- 1.3 Absolute Maximum Ratings**
- 1.4 Backlight & LED Characteristics**

2. MODULE STRUCTURE

- 2.1 Counter Drawing**
- 2.2 Interface Pin Description**
- 2.3 Timing Characteristics**
- 2.4 Instruction Table**
- 2.5 Inspection Specification**



Radiant Electronics Limited

Rm U,13/F., Block 1, Kinho Ind. Bldg., 14 Au Pui Wan St., Shatin N.T. Hong Kong

www.radisplay.com

E-mail: info@radiant-display.com

Tel:(852)29470031

Fax:(852)29470881

1. SPECIFICATIONS

1.1 Features

Item	Standard Value
Display Type	128X64 DOTS
Driver Condition	LCD Module : 1/64Duty , 1/9Bias
Viewing Direction	6 O'clock
Interface	8BIT bus MPU interface
Driver IC	T6963 or eqv

Model No.:	Color	LCD Type	Backlight Type
RD12864F-B	White on Blue	STN, NEGATIVE (BLUE), TRANSMISSIVE	SIDE WHITE
RD12864F-Y	Black on Yellow-Green	STN, POSITIVE (Y-G), TRANSFLECTIVE	SIDE Y-G
RD12864F-G	Black on Gray	STN, POSITIVE (GRAY), TRANSFLECTIVE	SIDE WHITE

1.2 Mechanical Specifications

Item	Standard Value	Unit
Outline Dimension	78(L) *70(W) * Max 12.3 (T)	mm
Viewing Area	62(L) * 44 (W)	mm
Dot size	0.4(W) × 0.56(H)	mm
Dot pitch	0.44(W) × 0.6(H)	mm

1.3 Absolute Maximum Ratings

Item	Symbol	Condition	Min.	Max.	Unit
System Power Supply Voltage	VDD	-	-0.3	5.5	V
LCD Driver Supply Voltage	VOUT _{IN}	-	4.8	5.0	V
Input Voltage	V _{IN}	-	-0.3	VDD + 0.2	V
Operating Temperature	T _{OP}	-	-20	70	°C



Radiant Electronics Limited

Rm U,13/F., Block 1, Kinho Ind. Bldg., 14 Au Pui Wan St., Shatin N.T. Hong Kong

www.radisplay.com

E-mail: info@radiant-display.com

Tel:(852)29470031

Fax:(852)29470881

Storage Temperature	T _{ST}	-	-30	80	°C
Storage Humidity	H _D	Ta < 40 °C	20	90	%RH

1.4 Backlight Characteristics

LCD Module without LED Backlight

Electrical / Optical Characteristics

Ta =25°C

Item	Symbol	Conditions	Min.	Typ.	Max.	Unit
Forward Voltage	V _f	I _f =80mA	3.0	3.1	3.2	V
Reverse Current	I _r	I _f =5v			--	uA
Average Brightness	I _V	I _f =80mA				cd/m ²
Wavelength (Without LCD)	λ _d	I _f =80mA	--	--	--	nm
Luminous Intensity (without LCD)	L _v Sub	I _f =80mA				cd/m ²
Uniformity	Δ%	I _v Min / I _v Max *100%	--	-	-	%

Radiant Electronics Limited



Rm U,13/F., Block 1, Kinho Ind. Bldg., 14 Au Pui Wan St., Shatin N.T. Hong Kong

www.radisplay.com

E-mail: info@radiant-display.com

Tel:(852)29470031

Fax:(852)29470881

2. MODULE STRUCTURE

2.1 Counter Drawing

2.1.1 LCM Mechanical Diagram

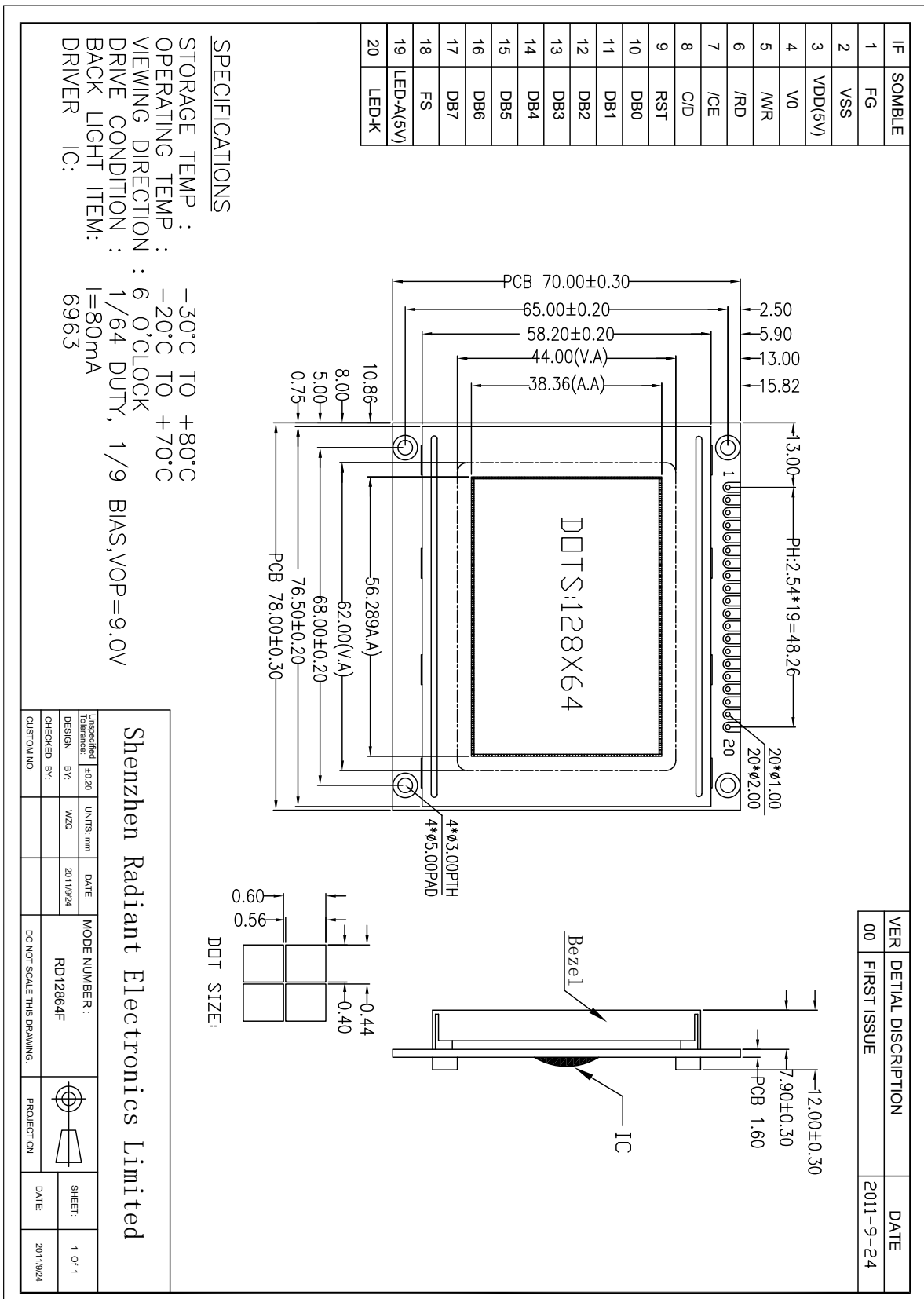



Radiant Electronics Limited

Rm U,13/F., Block 1, Kinho Ind. Bldg., 14 Au Pui Wan St., Shatin N.T. Hong Kong

www.radisplay.com

E-mail: info@radiant-display.com

Tel:(852)29470031

Fax:(852)29470881

2.2 Interface Pin Description

Pin No.	Symbol	Function
1	FG	Frame(Bezel)
2	VSS	Ground (0V)
3	VDD	Power supply input for driver IC (+5V)
4	VO	LCD driver supply voltages, Contrast Adjust
5	/WR	Data write, Write data into T6963C when WR=L
6	/RD	Data read, Read data from T6963C when RD=L
7	/CE	L: Chip enable
8	C/D	WR=L,C/D=H: Command Write C/D=L:Data write RD=L,C/D=H: Status Read C/D=L:Data read
9	RST	H: Normal L:Initialize
10--17	DB0~DB7	Data bus line
18	FS	Pins for selection of font, H=6X8, L=8X8
19	LED+	BACKLIGHT+ (5V)
20	LED-	BACKLIGHT- (0V)



Radiant Electronics Limited

Rm U,13/F., Block 1, Kinho Ind. Bldg., 14 Au Pui Wan St., Shatin N.T. Hong Kong

www.radisplay.com

E-mail: info@radiant-display.com

Tel:(852)29470031

Fax:(852)29470881

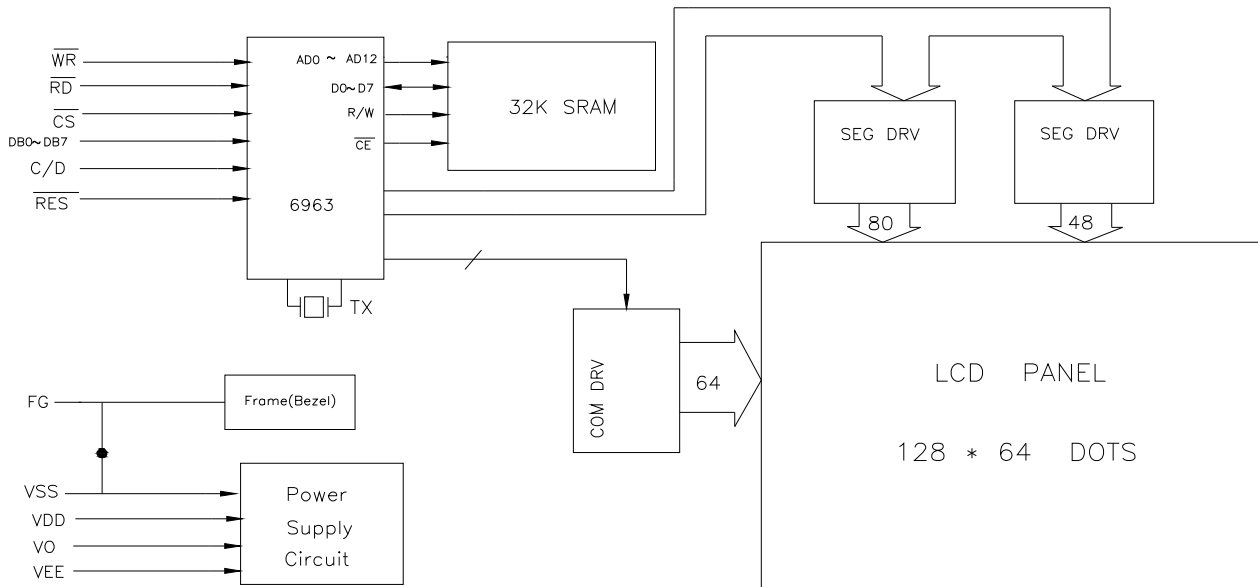



Radiant Electronics Limited

Rm U,13/F., Block 1, Kinho Ind. Bldg., 14 Au Pui Wan St., Shatin N.T. Hong Kong

www.radisplay.com

E-mail: info@radiant-display.com

Tel:(852)29470031

Fax:(852)29470881

2.3 Timing Characteristics

AC Characteristics

Bus Timing

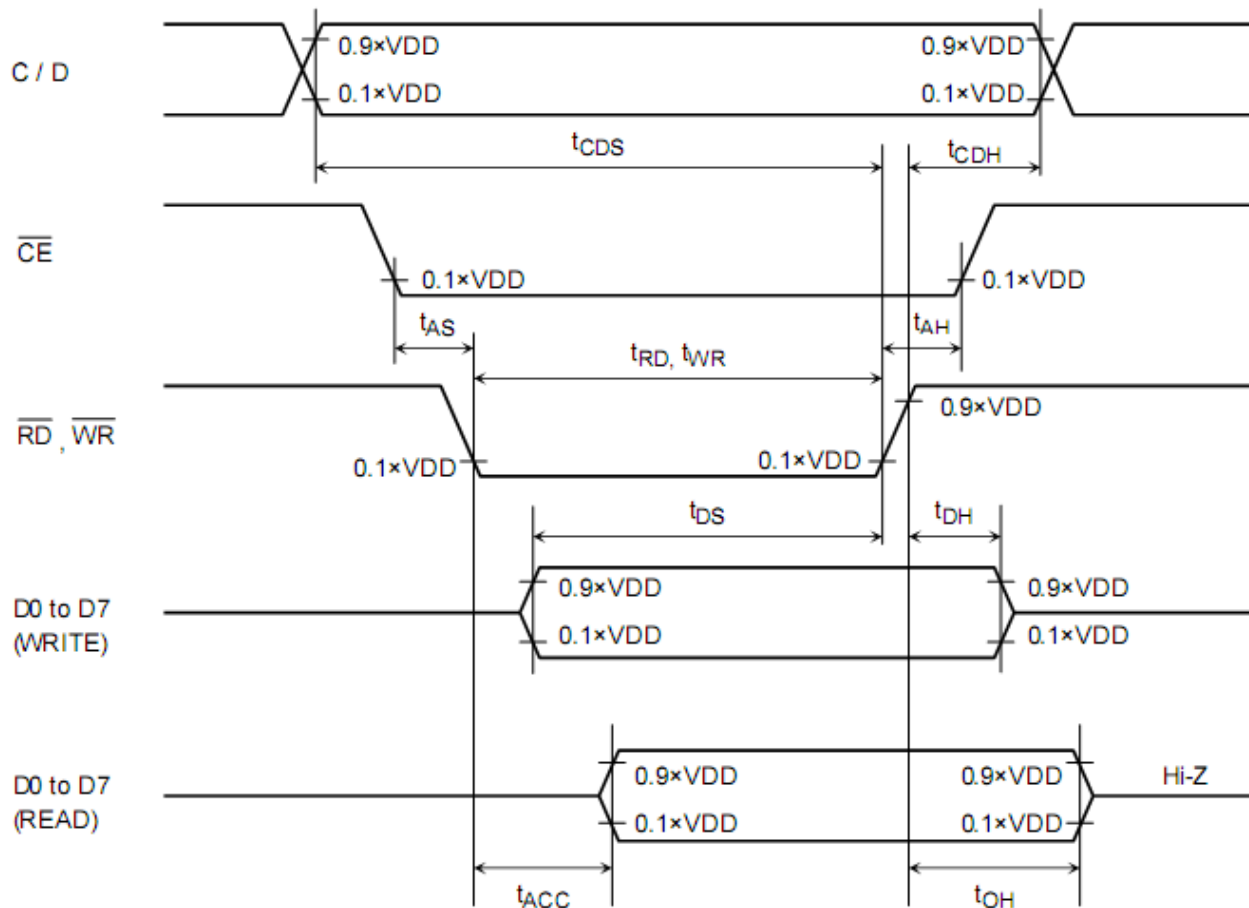

◆ **Test Conditions (Unless Otherwise Noted, $V_{DD} = 5.0\text{ V} \pm 10\%$, $V_{SS} = 0\text{ V}$, $T_a = -20\text{ to }75^\circ\text{C}$)**

Item	Symbol	Test Conditions	Min	Max	Unit
C / D Set-up Time	t_{CDS}	—	100	—	ns
C / D Hold Time	t_{CDH}	—	10	—	ns
\overline{RD} , \overline{WR} Pulse Width	t_{RD} , t_{WR}	—	80	—	ns
Address Set-up Time	t_{AS}	—	0	—	ns
Address Hold Time	t_{AH}	—	0	—	ns
Data Set-up Time	t_{DS}	—	80	—	ns
Data Hold Time	t_{DH}	(Note)	40	—	ns
Access Time	t_{ACC}	(Note)	—	150	ns
Output Hold Time	t_{OH}	(Note)	10	50	ns



Radiant Electronics Limited

Rm U,13/F., Block 1, Kinho Ind. Bldg., 14 Au Pui Wan St., Shatin N.T. Hong Kong

www.radisplay.com

E-mail: info@radiant-display.com

Tel:(852)29470031

Fax:(852)29470881

(1) External RAM Read mode

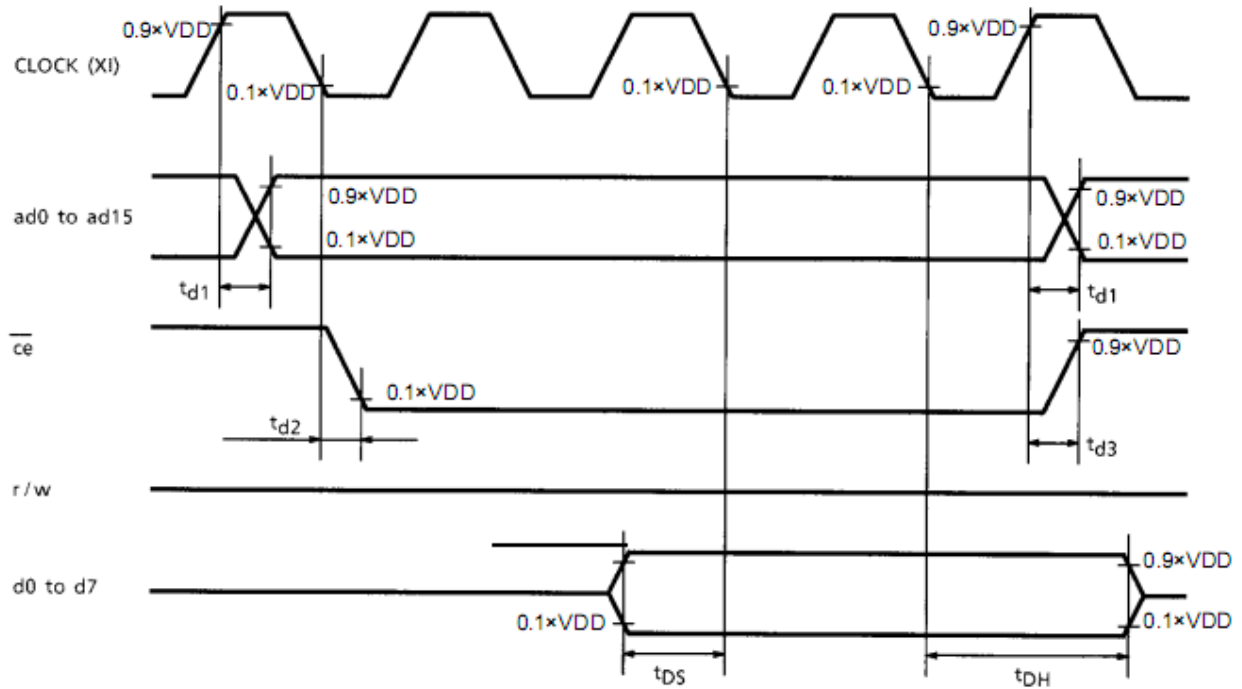

(2) External RAM Write mode

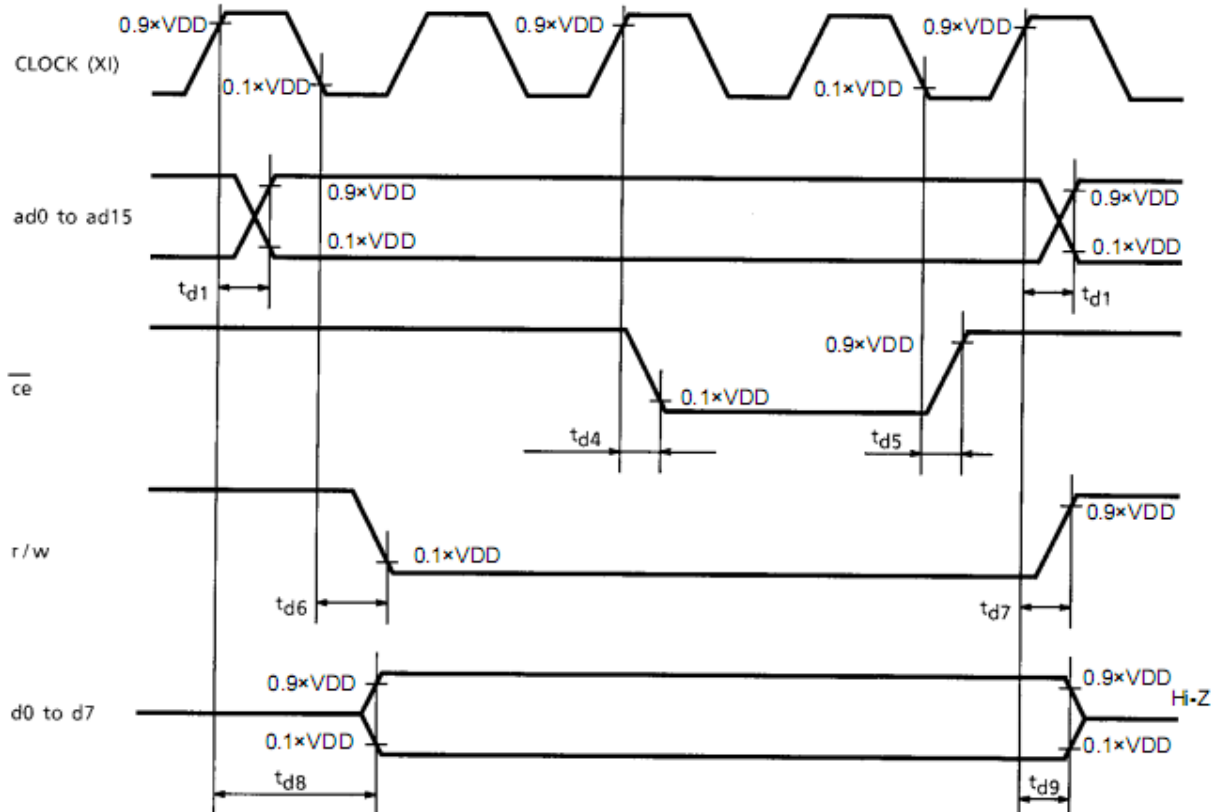



Radiant Electronics Limited

Rm U,13/F., Block 1, Kinho Ind. Bldg., 14 Au Pui Wan St., Shatin N.T. Hong Kong

www.radisplay.com

E-mail: info@radiant-display.com

Tel:(852)29470031

Fax:(852)29470881

Test Conditions (Unless Otherwise Noted, $V_{DD} = 5.0\text{ V} \pm 10\%$, $V_{SS} = 0\text{ V}$, $T_a = -20\text{ to }70^\circ\text{C}$)

Item	Symbol	Test Conditions	Min	Max	Unit
Address Delay Time	t_{d1}	—	—	250	ns
\overline{ce} Fall Delay Time (Read)	t_{d2}	—	—	180	ns
\overline{ce} Rise Delay Time (Read)	t_{d3}	—	—	180	ns
Data Set-up Time	t_{dS}	—	0	—	ns
Data Hold Time	t_{dH}	—	30	—	ns
\overline{ce} Fall Delay Time (Write)	t_{d4}	—	—	200	ns
\overline{ce} Rise Delay Time (Write)	t_{d5}	—	—	200	ns
r / w Fall Delay Time	t_{d6}	—	—	180	ns
r / w Rise Delay Time	t_{d7}	—	—	180	ns
Data Stable Time	t_{d8}	(Note)	—	450	ns
Data Hold Time	t_{d9}	—	—	200	ns

DC Characteristics

Test Conditions (Unless Otherwise Noted, $V_{SS} = 0\text{ V}$, $V_{DD} = 5.0\text{ V} \pm 10\%$, $T_a = -20\text{ to }75^\circ\text{C}$)

Item	Symbol	Test Circuit	Test Condition	Min	Typ.	Max	Unit	Pin Name
Operating Voltage	V_{DD}	—	—	4.5	5.0	5.5	V	V_{DD}
Input	H Level	V_{IH}	—	$V_{DD} - 2.2$	—	V_{DD}	V	Input pins
	L Level	V_{IL}	—	0	—	0.8	V	Input pins
Output Voltage	H Level	V_{OH}	—	$V_{DD} - 0.3$	—	V_{DD}	V	Output pins
	L Level	V_{OL}	—	0	—	0.3	V	Output pins
Output Resistance	H Level	R_{OH}	$V_{OUT} = V_{DD} - 0.5\text{ V}$	—	—	400	Ω	Output pins
	L Level	R_{OL}	$V_{OUT} = 0.5\text{ V}$	—	—	400	Ω	Output pins
Input Pull-up Resistance	RPU	—	—	50	100	200	k Ω	(Note 1)
Operating Frequency	f_{OSC}	—	—	0.4	—	5.5	MHz	
Current Consumption (Operating)	$I_{DD} (1)$	—	$V_{DD} = 5.0\text{ V}$ $f_{OSC} = 3.0\text{ MHz}$ (Note 2)	—	3.3	6	mA	V_{DD}
Current Consumption (Halt)	$I_{DD} (2)$	—	$V_{DD} = 5.0\text{ V}$	—	—	3	μA	V_{DD}

Note 1: Applied $\overline{T1}$, $\overline{T2}$, \overline{RESET}

Note 2: $MDS = L$, $MD0 = L$, $MD1 = L$, $MD2 = H$, $MD3 = H$, $FS0 = L$, $FS1 = L$, $\overline{SDSEL} = L$, $\overline{DUAL} = H$,
D7 to D0 = LHLHLHLH



Radiant Electronics Limited

Rm U,13/F., Block 1, Kinho Ind. Bldg., 14 Au Pui Wan St., Shatin N.T. Hong Kong

www.radisplay.com

E-mail: info@radiant-display.com

Tel:(852)29470031

Fax:(852)29470881

2.4 Instruction Table

Command	Code	D1	D2	Function
REGISTERS SETTING	00100001 00100010 00100100	X address Data Low address	Y address 00H High address	Set Cursor Pointer Set Offset Register Set Address Pointer
SET CONTROL WORD	01000000 01000001 01000010 01000011	Low address Columns Low address Columns	High address 00H High address 00H	Set Text Home Address Set Text Area Set Graphic Home Address Set Graphic Area
MODE SET	1000X000 1000X001 1000X011 1000X100 10000XXX 10001XXX	— — — — — —	— — — — — —	OR mode EXOR mode AND mode Text Attribute mode Internal CG ROM mode External CG RAM mode
DISPLAY MODE	10010000 1001XX10 1001XX11 100101XX 100110XX 100111XX	— — — — — —	— — — — — —	Display off Cursor on, blink off Cursor on, blink on Text on, graphic off Text off, graphic on Text on, graphic on
CURSOR PATTERN SELECT	10100000 10100001 10100010 10100011 10100100 10100101 10100110 10100111	— — — — — — — —	— — — — — — — —	1-line cursor 2-line cursor 3-line cursor 4-line cursor 5-line cursor 6-line cursor 7-line cursor 8-line cursor
DATA AUTO READ / WRITE	10110000 10110001 10110010	— — —	— — —	Set Data Auto Write Set Data Auto Read Auto Reset
DATA READ / WRITE	11000000 11000001 11000010 11000011 11000100 11000101	Data — Data — Data —	— — — — — —	Data Write and Increment ADP Data Read and Increment ADP Data Write and Decrement ADP Data Read and Decrement ADP Data Write and Nonvariable ADP Data Read and Nonvariable ADP
SCREEN PEEK	11100000	—	—	Screen Peek
SCREEN COPY	11101000			Screen Copy

X: invalid

Command	Code	D1	D2	Function
BIT SET / RESET	11110XXX 11111XXX 1111X000 1111X001 1111X010 1111X011 1111X100 1111X101 1111X110 1111X111	— — — — — — — — — —	— — — — — — — — — —	Bit Reset Bit Set Bit 0 (LSB) Bit 1 Bit 2 Bit 3 Bit 4 Bit 5 Bit 6 Bit 7 (MSB)

X: invalid



Radiant Electronics Limited

Rm U,13/F., Block 1, Kinho Ind. Bldg., 14 Au Pui Wan St., Shatin N.T. Hong Kong

www.radisplay.com

E-mail: info@radiant-display.com

Tel:(852)29470031

Fax:(852)29470881

• Setting registers

Code	Hex.	Function	D1	D2
00100001	21H	SET CURSOR POINTER	X ADRS	Y ADRS
00100010	22H	SET OFFSET REGISTER	DATA	00H
00100100	24H	SET ADDRESS POINTER	LOW ADRS	HIGH ADRS

(1) Set Cursor Pointer

The position of the cursor is specified by X ADRS and Y ADRS. The cursor position can only be moved by this command. Data read / write from the MPU never changes the cursor pointer. X ADRS and Y ADRS are specified as follows.

X ADRS 00H to 4FH (lower 7 bits are valid)

Y ADRS 00H to 1FH (lower 5 bits are valid)

`\(Rhmfdh Rb`m`

`W @CQR // sn 3EG`

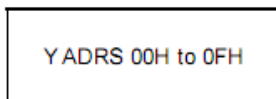

`b(Ct`kh Rb`m`

`W @CQR //G sn 3EG`

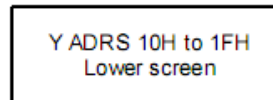
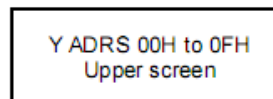

(2) Set Offset Register

The offset register is used to determine the external character generator RAM area.

The T6963CFG has a 16-bit address bus as follows:

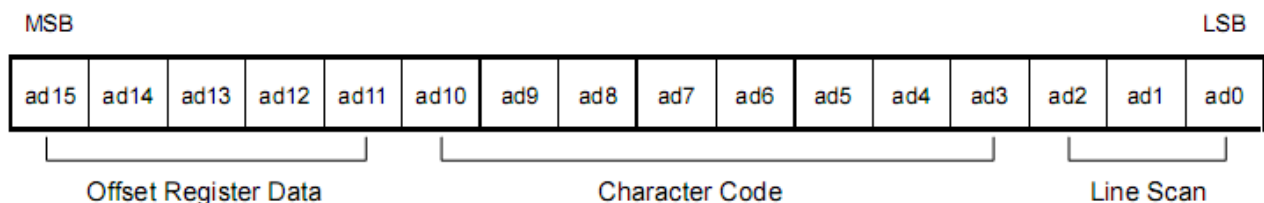



Radiant Electronics Limited

Rm U,13/F., Block 1, Kinho Ind. Bldg., 14 Au Pui Wan St., Shatin N.T. Hong Kong

www.radisplay.com

E-mail: info@radiant-display.com

Tel:(852)29470031

Fax:(852)29470881

11100	E000 to E7FFH
11101	E800 to EFFFH
11110	F000 to F7FFH
11111	F800 to FFFFH

(Example 1)

Offset register	02H				
Character code	80H				
Character generator RAM start address	0001	0100	0000	0000	
	1	4	0	0	H

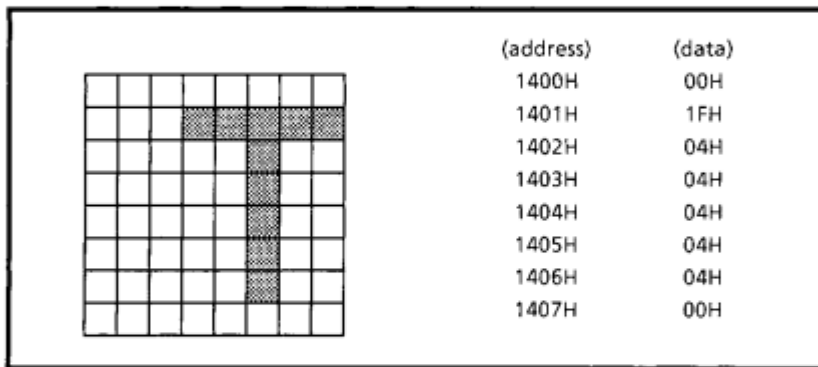

(Example 2) The relationship between display RAM data and display characters

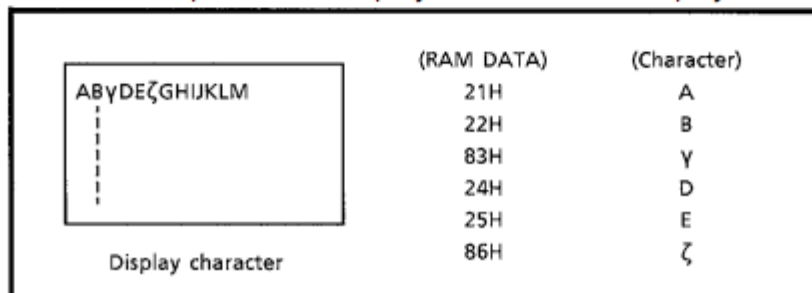

γ and ζ are displayed by character generator RAM.



Radiant Electronics Limited

Rm U,13/F., Block 1, Kinho Ind. Bldg., 14 Au Pui Wan St., Shatin N.T. Hong Kong

www.radisplay.com

E-mail: info@radiant-display.com

Tel:(852)29470031

Fax:(852)29470881

(3) Set Address Pointer

The Set Address Pointer command is used to indicate the start address for writing to (or reading from) external RAM.

`Sgd Eknvbg`qs enq Rds @ccqdr r Onhmsdq bnl l`mc`

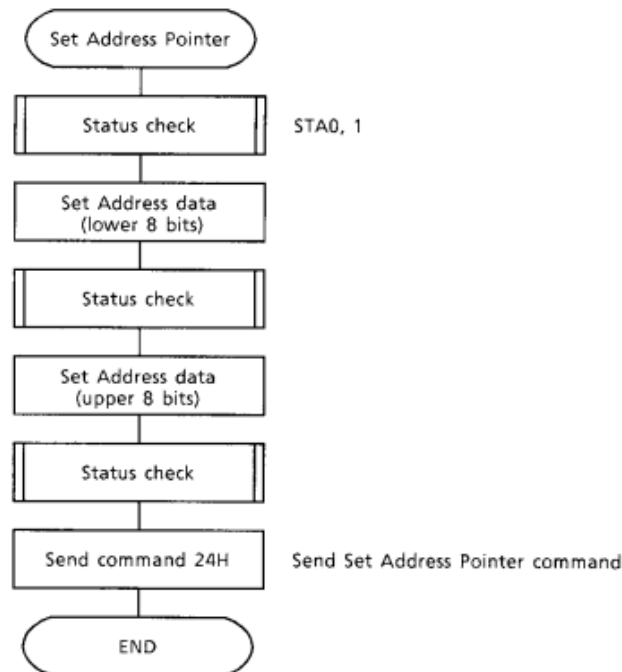

• Set Control Word

Code	Hex.	Function	D1	D2
01000000	40H	Set Text Home Address	Low address	High address
01000001	41H	Set Text Area	Columns	00H
01000010	42H	Set Graphic Home Address	Low address	High address
01000011	43H	Set Graphic Area	Columns	00H

The home address and column size are defined by this command.

(1) Set Text Home Address

The starting address in the external display RAM for text display is defined by this command. The text home address indicates the leftmost and uppermost position.

`Sgd qdk`shnmrg ho adsvddm dwsdq`k chrok`x Q@L `ccqdr r `mc chrok`x onrhshnm`

TH		TH + CL
TH + TA		TH + TA + CL
(TH + TA) + TA		TH + 2TA + CL
(TH + 2TA) + TA		TH + 3TA + CL
TH + (n - 1) TA		TH + (n - 1) TA + CL



Radiant Electronics Limited

Rm U,13/F., Block 1, Kinho Ind. Bldg., 14 Au Pui Wan St., Shatin N.T. Hong Kong

www.radisplay.com

E-mail: info@radiant-display.com

Tel:(852)29470031

Fax:(852)29470881

TH: Text home address

TA: Text area number (columns)

CL: Columns are fixed by hardware (pin-programmable).

(Example)

Text home address : 0000H
 Text area : 0020H
 MD2 = H, MD3 = H : 32 columns
 DUAL = H, MDS = L, MD0 = L, MD1 = H: 4 lines

0000H	0001H		001EH	001FH
0020H	0021H		003EH	002FH
0040H	0041H		005EH	005FH
0060H	0061H		007EH	007FH

(2) Set Graphic Home Address

The starting address of the external display RAM used for graphic display is defined by this command. The graphic home address indicates the leftmost and uppermost position.

Sgd qdk`shnmrg`ho adsvddm dwsdqm`k chrok`x Q@L `ccqdr`mc chrok`x onrhshnm

GH		GH + CL
GH + GA		GH + GA + CL
(GH + GA) + GA		GH + 2GA + CL
(GH + 2GA) + GA		GH + 3GA + CL
GH + (n - 1) GA		GH + (n - 1) GA + CL

GH: Graphic home address

GA: Graphic area number (columns)

CL: Columns are fixed by hardware (pin-programmable).

(Example)

Graphic home address : 0000H
 Graphic area : 0020H
 MD2 = H, MD3 = H : 32 columns
 DUAL = H, MDS = L, MD0 = H, MD1 = H: 2 lines



Radiant Electronics Limited

Rm U,13/F., Block 1, Kinho Ind. Bldg., 14 Au Pui Wan St., Shatin N.T. Hong Kong

www.radisplay.com

E-mail: info@radiant-display.com

Tel:(852)29470031

Fax:(852)29470881

0000H	0001H		001EH	001FH
0020H	0021H		003EH	003FH
0040H	0041H		005EH	005FH
0060H	0061H		007EH	007FH
0080H	0081H		009EH	009FH
00A0H	00A1H		00BEH	00BFH
00C0H	00C1H		00DEH	00DFH
00E0H	00E1H		00FEH	00FFH
0100H	0101H		011EH	011FH
0120H	0121H		013EH	013FH
0140H	0141H		015EH	015FH
0160H	0161H		017EH	017FH
0180H	0181H		019EH	019FH
01A0H	01A1H		01BEH	01BFH
01C0H	01C1H		01DEH	01DFH
01E0H	01E1H		01FEH	01FFH

(3) Set Text Area

The display columns are defined by the hardware setting. This command can be used to adjust the columns of the display.

(Example)

LCD size : 20 columns, 4 lines
 Text home address : 0000H
 Text area : 0014H
 MD2 = H, MD3 = H : 32 columns
 DUAL = H, MDS = L, MD0 = L, MD1 = H : 4 lines

0000	0001	0013	0014	001F
0014	0015	0027	0028	0033
0028	0029	003B	003C	0047
003C	003D	004F	0050	005B

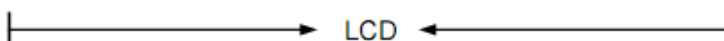

(4) Set Graphic Area

The display columns are defined by the hardware setting. This command can be used to adjust the columns of the graphic display.



Radiant Electronics Limited

Rm U,13/F., Block 1, Kinho Ind. Bldg., 14 Au Pui Wan St., Shatin N.T. Hong Kong

www.radisplay.com

E-mail: info@radiant-display.com

Tel:(852)29470031

Fax:(852)29470881

(Example)

LCD size : 20 columns, 2 lines
 Graphic home address : 0000H
 Graphic area : 0014H
 MD2 = H, MD3 = H : 32 columns
 DUAL = H, MDS = L, MD0 = H, MD1 = H : 2 lines

0000	0001	0013	0014	001F
0014	0015	0027	0028	0033
0028	0029	003B	003C	0047
003C	003D	004F	0050	005B
0050	0051	0063	0064	006F
0064	0065	0077	0078	0083
0078	0079	008B	008C	0097
008C	008D	009F	00A0	00AB
00A0	00A1	00B3	00B4	00BF
00B4	00B5	00C7	00C8	00D3
00C8	00C9	00DB	00DC	00E7
00DC	00DD	00EF	00F0	00FD
00F0	00F1	0103	0104	011F
0104	0105	0127	0128	0123
0128	0129	013B	013C	0147
013C	013D	014F	0150	015B

If the graphic area setting is set to match the desired number of columns on the LCD, the addressing scheme will be automatically modified so that the start address of each line equals the end address of the previous line + 1.

● **Mode set**

Code	Function	Operand
1000X000	OR Mode	—
1000X001	EXOR Mode	—
1000X011	AND Mode	—
1000X100	TEXT ATTRIBUTE Mode	—
10000XXX	Internal Character Generator Mode	—
10001XXX	External Character Generator Mode	—

X: invalid

The display mode is defined by this command. The display mode does not change until the next command is sent. The logical OR, EXOR, AND of text or graphic display can be displayed.

In Internal Character Generator mode, character codes 00H to 7FH are assigned to the built-in character generator ROM. The character codes 80H to FFH are automatically assigned to the external character generator RAM.



Radiant Electronics Limited

Rm U,13/F., Block 1, Kinho Ind. Bldg., 14 Au Pui Wan St., Shatin N.T. Hong Kong

www.radisplay.com

E-mail: info@radiant-display.com

Tel:(852)29470031

Fax:(852)29470881

(Example)

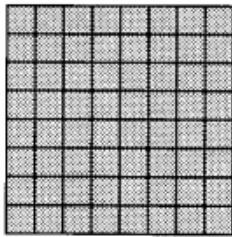

GRAPHIC

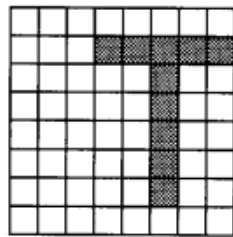

TEXT

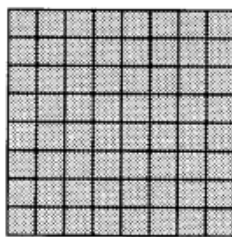

"OR"

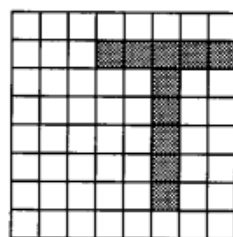

"AND"

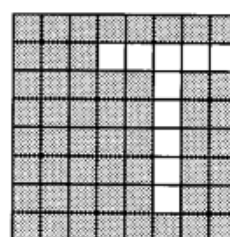

"EXOR"

Note: Attribute functions can only be applied to text display, since the attribute data is placed in the graphic RAM area.

The attribute operations are Reverse display, Character blink and Inhibit. The attribute data is written into the graphic area which was defined by the Set Control Word command. Only text display is possible in Attribute Function mode; graphic display is automatically disabled. However, the Display Mode command must be used to turn both Text and Graphic on in order for the Attribute function to be available. The attribute data for each character in the text area is written to the same address in the graphic area. The Attribute function is defined as follows.

Attribute RAM 1byte

X	X	X	X	d3	d2	d1	d0
---	---	---	---	----	----	----	----

d3	d2	d1	d0	Function
0	0	0	0	Normal display
0	1	0	1	Reverse display
0	0	1	1	Inhibit display
1	0	0	0	Blink of normal display
1	1	0	1	Blink of reverse display
1	0	1	1	Blink of inhibit display

X: invalid



Radiant Electronics Limited

Rm U,13/F., Block 1, Kinho Ind. Bldg., 14 Au Pui Wan St., Shatin N.T. Hong Kong

www.radisplay.com

E-mail: info@radiant-display.com

Tel:(852)29470031

Fax:(852)29470881

• Display mode

Code	Function	Operand
10010000	Display off	—
1001XX10	Cursor on, blink off	—
1001XX11	Cursor on, blink on	—
100101XX	Text on, graphic off	—
100110XX	Text off, graphic on	—
100111XX	Text on, graphic on	—

X: invalid

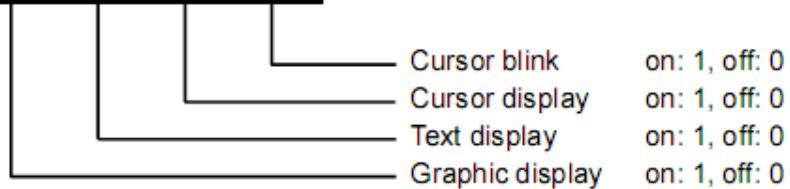
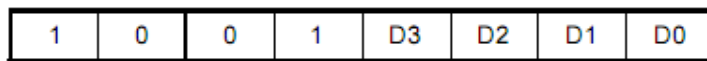

Note: It is necessary to turn on "Text display" and "Graphic display" in the following cases.

- Combination of text / graphic display
- Attribute function

• Cursor pattern select

Code	Function	Operand
10100000	1-line cursor	—
10100001	2-line cursor	—
10100010	3-line cursor	—
10100011	4-line cursor	—
10100100	5-line cursor	—
10100101	6-line cursor	—
10100110	7-line cursor	—
10100111	8-line cursor	—

When cursor display is ON, this command selects the cursor pattern in the range 1 line to 8 lines. The cursor address is defined by the Cursor Pointer Set command.

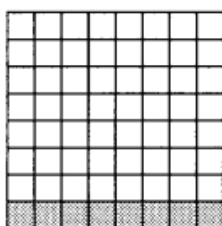

1-line cursor

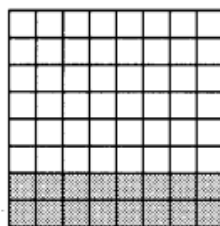

2-line cursor

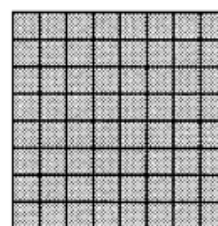

8-line cursor



Radiant Electronics Limited

Rm U,13/F., Block 1, Kinho Ind. Bldg., 14 Au Pui Wan St., Shatin N.T. Hong Kong

www.radisplay.com

E-mail: info@radiant-display.com

Tel:(852)29470031

Fax:(852)29470881

• Data Auto Read / Write

Code	Hex.	Function	Operand
10110000	B0H	Set Data Auto Write	—
10110001	B1H	Set Data Auto Read	—
10110010	B2H	Auto Reset	—

This command is convenient for sending a full screen of data from the external display RAM. After setting Auto mode, a Data Write (or Read) command is need not be sent between each datum. A Data Auto Write (or Read) command must be sent after a Set Address Pointer command. After this command, the address pointer is automatically incremented by 1 after each datum. In Auto mode, the T6963CFG cannot accept any other commands.

The Auto Reset command must be sent to the T6963CFG after all data has been sent, to clear Auto mode.

Note: A Status check for Auto mode

(STA2, STA3 should be checked between sending of each datum. Auto Reset should be performed after checking STA3 = 1 (STA2 = 1). Refer to the following flowchart.

a) Auto Read mode

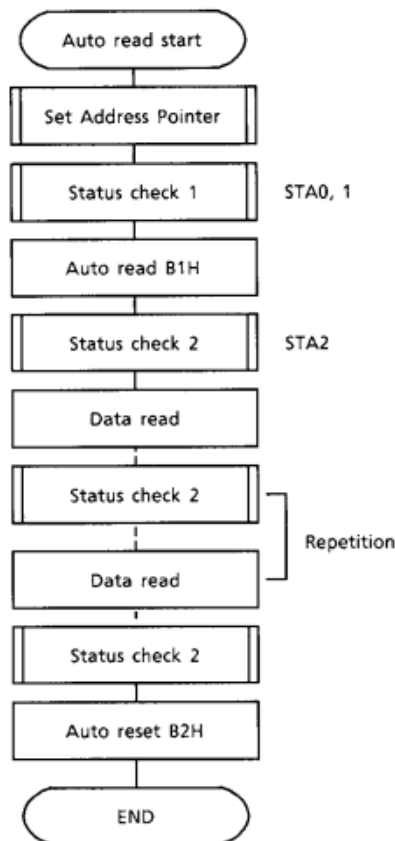

b) Auto Write mode

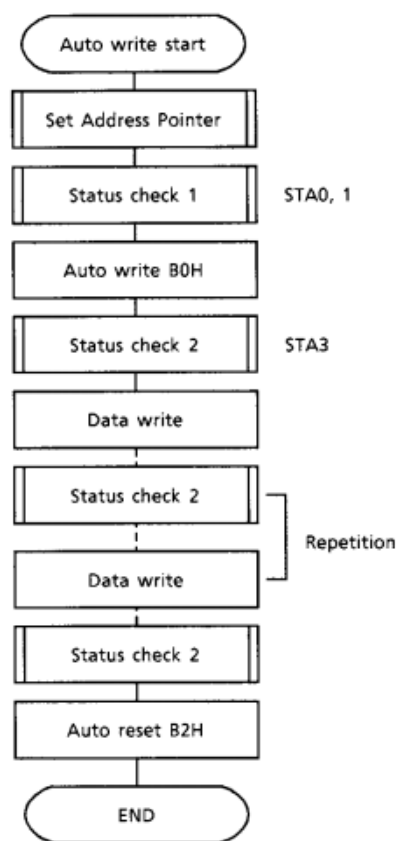



Radiant Electronics Limited

Rm U,13/F., Block 1, Kinho Ind. Bldg., 14 Au Pui Wan St., Shatin N.T. Hong Kong

www.radisplay.com

E-mail: info@radiant-display.com

Tel:(852)29470031

Fax:(852)29470881

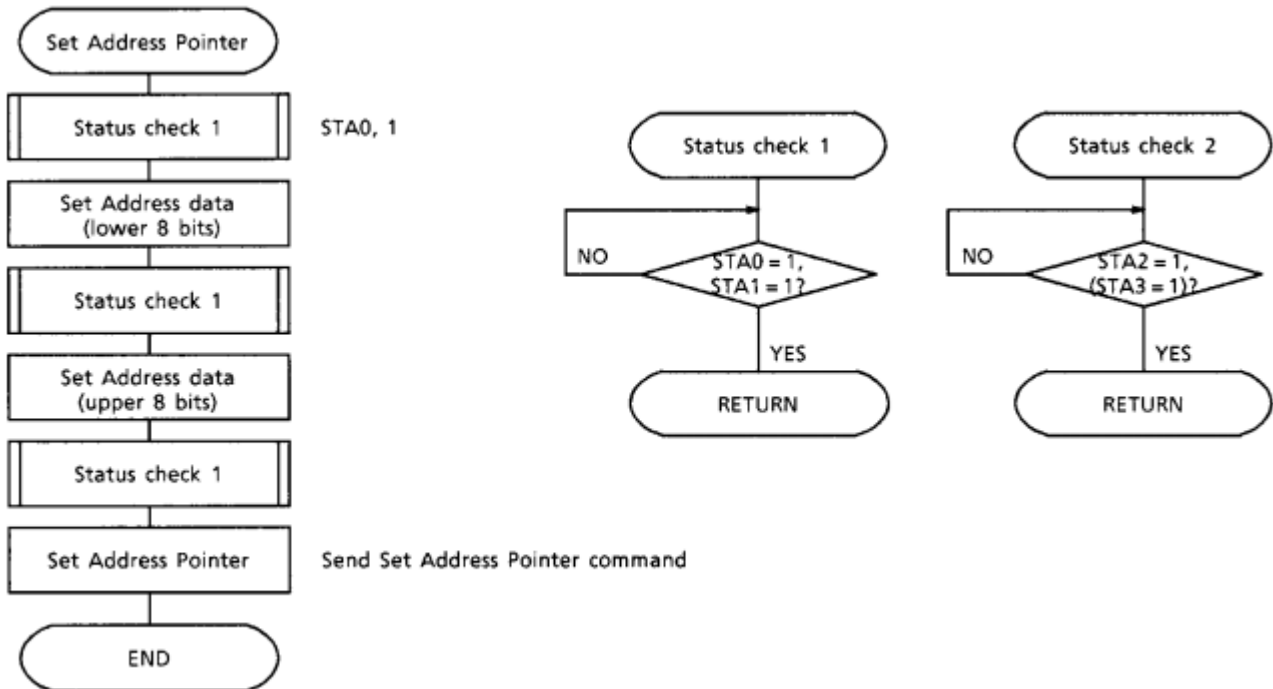

• Data Read / Write

Code	Hex.	Function	Operand
11000000	C0H	Data Write and Increment ADP	Data
11000001	C1H	Data Read and Increment ADP	—
11000010	C2H	Data Write and Decrement ADP	Data
11000011	C3H	Data Read and Decrement ADP	—
11000100	C4H	Data Write and Nonvariable ADP	Data
11000101	C5H	Data Read and Nonvariable ADP	—

This command is used for writing data from the MPU to external display RAM, and reading data from external display RAM to the MPU. Data Write / Data Read should be executed after setting address using Set Address Pointer command. The address pointer can be automatically incremented or decremented using this command.

Note: This command is necessary for each 1-byte datum.
Refer to the following flowchart.

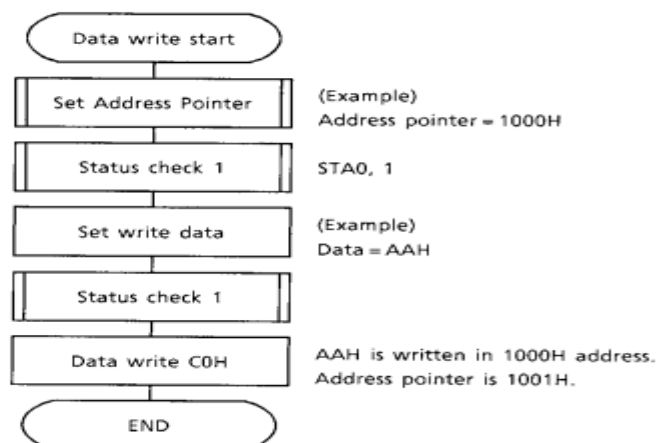



Radiant Electronics Limited

Rm U,13/F., Block 1, Kinho Ind. Bldg., 14 Au Pui Wan St., Shatin N.T. Hong Kong

www.radisplay.com

E-mail: info@radiant-display.com

Tel:(852)29470031

Fax:(852)29470881

• Screen Peek

Code	Hex.	Function	Operand
11100000	E0H	Screen Peek	—

This command is used to transfer 1 byte of displayed data to the data stack; this byte can then be read from the MPU by data access. The logical combination of text and graphic display data on the LCD screen can be read by this command.

The status (STA6) should be checked just after the Screen Peek command. If the address determined by the Set Address Pointer command is not in the graphic area, this command is ignored and a status flag (STA6) is set.

Refer to the following flowchart.

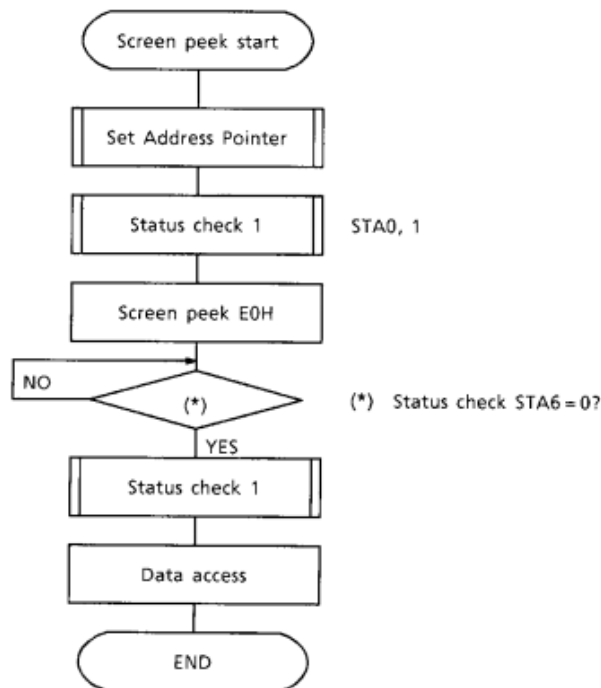

Note: This command is available when hardware column number and software column number are the same. Hardware column number is related to MD2 and MD3 setting. Software column number is related to Set Text Area and Set Graphic Area command.



Radiant Electronics Limited

Rm U,13/F., Block 1, Kinho Ind. Bldg., 14 Au Pui Wan St., Shatin N.T. Hong Kong

www.radisplay.com

E-mail: info@radiant-display.com

Tel:(852)29470031

Fax:(852)29470881

• Screen Copy

Code	Hex.	Function	Operand
11101000	E8H	Screen Copy	—

This command copies a single raster line of data to the graphic area.

The start point must be set using the Set Address Pointer command.

Note 1: If the attribute function is being used, this command is not available.

(With Attribute data is graphic area data.)

Note 2: With Dual-Scan, this command cannot be used (because the T6963CFG cannot separate the upper screen data and lower screen data).

Refer to the following flowchart.

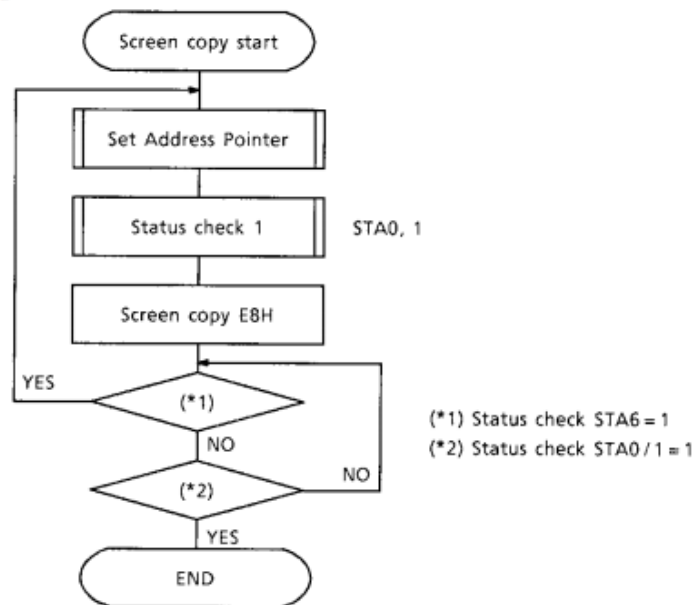

Note: This command is available when hardware column number and software column number are the same.

Hardware column number is related to MD2 and MD3 setting.

Software column number is related to Set Text Area and Set Graphic Area command.



Radiant Electronics Limited

Rm U,13/F., Block 1, Kinho Ind. Bldg., 14 Au Pui Wan St., Shatin N.T. Hong Kong

www.radisplay.com

E-mail: info@radiant-display.com

Tel:(852)29470031

Fax:(852)29470881

• Bit Set / Reset

Code	Function	Operand
11110XXX	Bit Reset	—
11111XXX	Bit Set	—
1111X000	Bit 0 (LSB)	—
1111X001	Bit 1	—
1111X010	Bit 2	—
1111X011	Bit 3	—
1111X100	Bit 4	—
1111X101	Bit 5	—
1111X110	Bit 6	—
1111X111	Bit 7 (MSB)	—

X: invalid

This command use to set or reset a bit of the byte specified by the address pointer. Only one bit can be set / reset at a time.

Refer to the following flowchart.

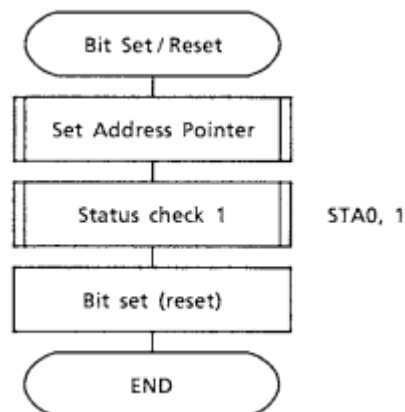



Radiant Electronics Limited

Rm U,13/F., Block 1, Kinho Ind. Bldg., 14 Au Pui Wan St., Shatin N.T. Hong Kong

www.radisplay.com

E-mail: info@radiant-display.com

Tel:(852)29470031

Fax:(852)29470881

Character Code Map

The relation between character codes and character pattern (CG ROM TYPE 0101)

MSB \ LSB	0	1	2	3	4	5	6	7	8	9	A	B	C	D	E	F
0		!	"	#	\$	%	&	'	()	*	+	,	-	.	/
1	0	1	2	3	4	5	6	7	8	9	:	;	<	=	>	?
2	a	H	E	C	D	E	F	G	H	I	J	K	L	M	N	O
3	P	Q	R	S	T	U	U	W	X	Y	Z	[\]	^	_
4	~	a	b	c	d	e	f	g	h	i	j	k	l	m	n	o
5	p	q	r	s	t	u	u	w	x	y	z	{		}	~	
6	0	0	0	0	0	0	0	0	0	0	0	0	0	0	0	0
7	0	0	0	0	0	0	0	0	0	0	0	0	0	0	0	0

2.5 Inspection Specification

- ◆ Inspection Standard : MIL-STD-105E Table Normal Inspection Single Sampling Level II .
- ◆ Equipment : Gauge、MIL-STD、Powertip Tester、Sample
- ◆ Defect Level : Major Defect AQL 0.4; Minor Defect AQL 1.5 .
- ◆ OUT Going Defect Level : Sampling .
- ◆ Manner of appearance test :
 - (1). The test be under 40W×2 fluorescent light ' and distance of view must be at 30 cm.
 - (2). The test direction is base on about around 45° of vertical line. (Fig. 1)
 - (3). Definition of area . (Fig. 2)



Radiant Electronics Limited

Rm U,13/F., Block 1, Kinho Ind. Bldg., 14 Au Pui Wan St., Shatin N.T. Hong Kong

www.radisplay.com

E-mail: info@radiant-display.com

Tel:(852)29470031

Fax:(852)29470881

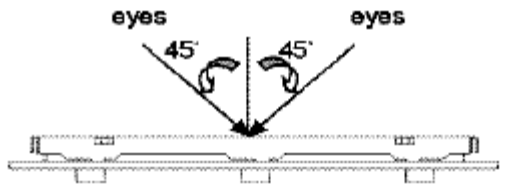

B area : Outside of viewing area

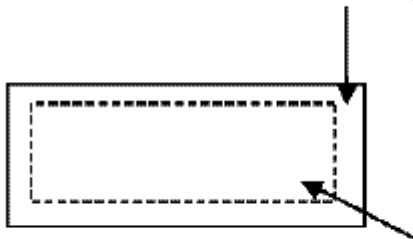

A area : viewing area

◆ Specification:

NO	Item	Criterion	level
01	Product condition	1.1 The part number is inconsistent with work order of Production.	Major
		1.2 Mixed production types.	Major
		1.3 Assembled in inverse direction.	Major
02	Quantity	2.1 The quantity is inconsistent with work order of production.	Major
03	Outline dimension	3.1 Product dimension and structure must conform to Structure diagram.	Major
04	Electrical Testing	4.1 Missing line character、 dot and icon.	Major
		4.2 No function or no display.	Major
		4.3 Output data is error.	Major
		4.4 LCD viewing angle defect.	Major
		4.5 Current consumption exceeds product specifications.	Major
05	Black or white dot、 scratch、 contamination Round type	5.1 Round type: 5.1.1 display only : ·White and black spots on display $\leq 0.25\text{mm}$, no more than Four white or black spots present. ·Densely spaced : NO more than two spots or lines within 3mm	Minor

◆ Specification :

NO	Item	Criterion	level
----	------	-----------	-------



Radiant Electronics Limited

Rm U,13/F., Block 1, Kinho Ind. Bldg., 14 Au Pui Wan St., Shatin N.T. Hong Kong

www.radisplay.com

E-mail: info@radiant-display.com

Tel:(852)29470031

Fax:(852)29470881

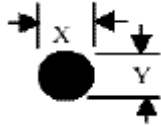
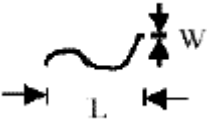
05	<p>Black or white dot、scratch、contamination Round type</p>  <p>$\Phi=(x+y)/2$</p> 	<p>5.1.2 Nom-display :</p> <p>Dimension (diameter : Φ) Acceptance(Q'ty)</p> <p>$\Phi \leq 0.10\text{mm}$ Accept no dense</p> <p>$0.10\text{mm} < \Phi \leq 0.20\text{mm}$ 3</p> <p>$0.20\text{mm} < \Phi \leq 0.25\text{mm}$ 2</p> <p>Total 4</p> <p>5.1.3 Line type: Dimension (diameter : Φ) Acceptance (Q'ty)</p> <p>Length width A area B area</p> <p>---</p> <p>$w \leq 0.03\text{mm}$ Accept no dense Don't count</p> <p>$L \leq 3.0\text{mm}$ $0.03\text{mm} < \Phi \leq 0.05\text{mm}$</p> <p>4</p> <p>Don't count</p> <p>$L \leq 2.5\text{mm}$ $0.05\text{mm} < \Phi \leq 0.075\text{mm}$</p> <p>Don't count</p> <p>---</p> <p>$w > 0.075\text{mm}$ As round type</p>	Minor
----	---------------------------------------------------------------------------------------------------------------------------------------------------------------------------------------------------------------------------------------------------------------------	----------------------------------------------------------------------------------------------------------------------------------------------------------------------------------------------------------------------------------------------------------------------------------------------------------------------------------------------------------------------------------------------------------------------------------------------------------------------------------------------------------------------------------------------------------------------------------------------------------------------------------------------------------------------------------------------------------------------------------------------------------------------------------------------------------------------------------------------------------------------------------	-------



Radiant Electronics Limited

Rm U,13/F., Block 1, Kinho Ind. Bldg., 14 Au Pui Wan St., Shatin N.T. Hong Kong

www.radisplay.com

E-mail: info@radiant-display.com

Tel:(852)29470031

Fax:(852)29470881

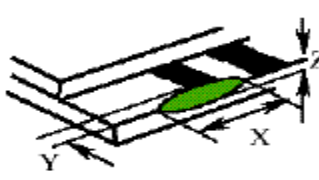
06	Polarizer Bubble	<p>Dimension (diameter : Φ)</p> <p>A area</p> <p>Acceptance(Q'ty)</p> <p>B area</p> <p>$\Phi \leq 0.20\text{mm}$</p> <p>Accept no dense</p> <p>Don't count</p> <p>$0.20\text{mm} < \Phi \leq 0.50\text{mm}$</p> <p>3</p> <p>Don't count</p> <p>$0.50\text{mm} < \Phi \leq 1.00\text{mm}$</p> <p>2</p> <p>Don't count</p> <p>$\Phi > 1.00\text{mm}$</p> <p>0</p> <p>Don't count</p> <p>Total quantity</p> <p>4</p> <p>Don't count</p>	Minor
07	The crack of glass	<p>● Glass Crack:</p> <p>7.1 Crack on the circuit of electrode terminal :</p>  <p>X</p> <p>Y</p> <p>Z</p> <p>Front</p> <p>$X \leq 1/5 a$</p> <p>$Y \leq 1/2 D$</p> <p>$Z \leq t$</p> <p>Back</p> <p>Neglect</p>	Minor



Radiant Electronics Limited

Rm U,13/F., Block 1, Kinho Ind. Bldg., 14 Au Pui Wan St., Shatin N.T. Hong Kong



www.radisplay.com

E-mail: info@radiant-display.com

Tel:(852)29470031

Fax:(852)29470881

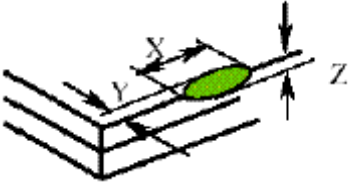
◆ Specification :

NO	Item	Criterion	Level
07	<p>The crack of glass</p> <p>X: The length of Crack</p> <p>Y: The width of crack</p> <p>Z: The thickness of crack</p> <p>D: terminal length</p> <p>T: The thickness of glass</p> <p>A : The length of glass</p>	<p>● Glass Crack:</p> <p>7.2 General glass crack and corner edge:</p> <p>7.2.1</p>  <p>X Y Z Neglect Out A area Neglect</p> <p>7.2.2</p>  <p>X Y Z Neglect Out A area Neglect</p>	Minor



Radiant Electronics Limited

Rm U,13/F., Block 1, Kinho Ind. Bldg., 14 Au Pui Wan St., Shatin N.T. Hong Kong

www.radisplay.com

E-mail: info@radiant-display.com

Tel:(852)29470031

Fax:(852)29470881

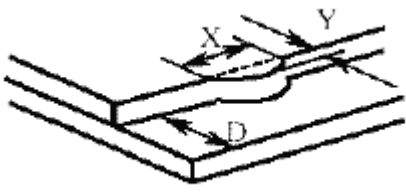
		<p>7.3 Glass remain:</p>  <p>X Y</p> <p>Neglect $\leq 1/3 d$</p>	Minor
--	--	-----------------------------------------------------------------------------------------------------------------------------------------------------------------------	-------

◆ Specification :

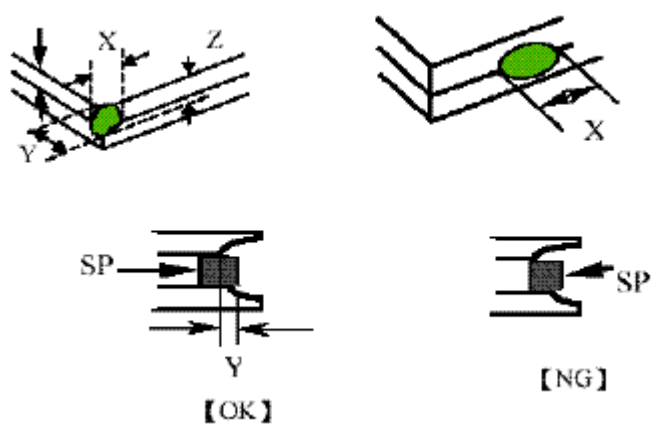
NO	Item	Criterion	Level
07	<p>The crack of glass</p> <p>X: The length of Crack</p> <p>Y: The width of crack</p> <p>Z: The thickness of crack</p> <p>D: terminal length</p> <p>T: The thickness of glass</p> <p>A : The length of glass</p>	<p>7.4 Corner crack and medial crack:</p>  <p>X Y Z $\leq 1/5a$</p> <p>Crack can't enter viewing area $\leq 1/2t$ $\leq 1/5a$</p> <p>Crack can't exceed the half of width of SP width of SP $1/2t < Z \leq 2t$</p>	Minor
08	Backlight elements	8.1 Backlight can't work normally.	Major
		8.2 Backlight doesn't light or color is wrong.	Major



Radiant Electronics Limited

Rm U,13/F., Block 1, Kinho Ind. Bldg., 14 Au Pui Wan St., Shatin N.T. Hong Kong

www.radisplay.com

E-mail: info@radiant-display.com

Tel:(852)29470031

Fax:(852)29470881

		8.3 Illumination source flickers when lit.	Major
09	General appearance	9.1 pin type must match type in specification sheet	Major
		9.2 No short circuits in components on PCB or FPC	Major
		9.3 Product packaging must be the same as specified on packaging specification sheet.	Major
		9.4 The folding and peeling off in polarizer are not acceptable	Major
		9.5 The PCB or FPC between B/L assembled distance (PCB or FPC) is $\leq 1.5\text{mm}$	Major